

Product Specification Sheet for:  
**Snail Springer 90840165RO**

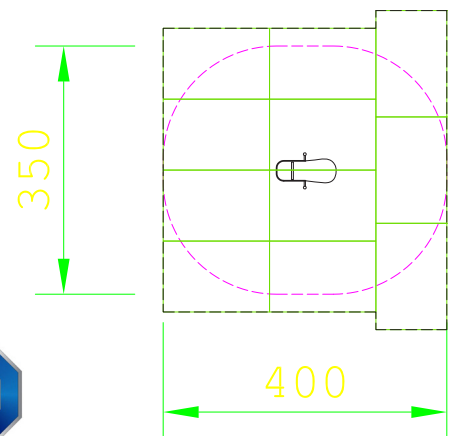

|                                  |   |
|----------------------------------|---|
| Product Name                     | Snail Springer                              |
| Product Code                     | 90840165RO                                  |
| Material                         | BS EN 350-02 Class 1 Robinia Timber         |
| Product Category                 | FHS Equipment for Small Children Springer   |
| Age Range                        | 2 to 6                                      |
| Product Type                     | Moving Springer                             |
| Fixings                          | Stainless Steel Fixings & Galvanised Plates |
| Free Space Area m2               | 11.80                                       |
| Free Space Loosefill m2          | 11.80                                       |
| FFH                              | 1.00  |
| Area Required (LxW)              | 4 x 3.5                                     |
| Grassmat Total (M <sup>2</sup> ) | 6   |

Plan View  
 Not to scale

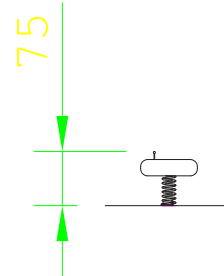

Compliant to EN1176

**Product Description**

The Snail Springer is designed for children aged 2-6 years. The design of our springers is based on creatures and items that young children can identify with such as animals. Our range of springers encourage children's imagination and allow them to experience a range of movement.

The Inclusive Play logo highlights the pieces of equipment most suitable to users of varying abilities.



Company No. SC200761  
 © Jupiter Play & Leisure Ltd. 2014.

[www.jupiterplay.co.uk](http://www.jupiterplay.co.uk)  
[info@jupiterplay.co.uk](mailto:info@jupiterplay.co.uk)

HEAD OFFICE: 0131 445 7989  
 SOUTHERN OFFICE: 0115 969 9859