

Product Specification Sheet for:  
**Ram Springer 90840170RO**



Product Name	Ram Springer
Product Code	90840170RO
Material	BS EN 350-02 Class 1 Robinia Timber
Product Category	FHS Equipment for Small Children Springer
Age Range	2 to 6
Product Type	Moving Springer
Fixings	Stainless Steel Fixings & Galvanised Plates
Free Space Area m2	11.80
Free Space Loosefill m2	11.80
FFH	1.00
Area Required (LxW)	4 x 3.5
Grassmat Total (M²)	6

**Product Description**

The Ram Springer is designed for children aged 2-6 years. The design of our springers is based on creatures and items that young children can identify with such as animals. Our range of springers encourage children's imagination and allow them to experience a range of movement.

Plan View  
 Not to scale

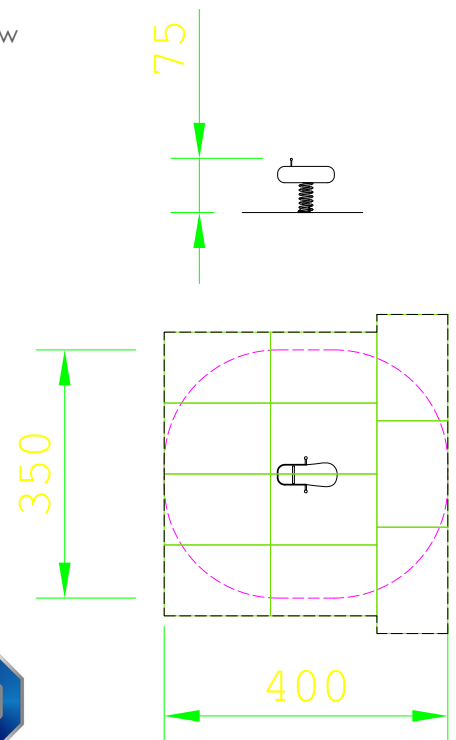

Compliant to EN1176