

Product Specification Sheet for:
Rhino Springer 90840225RO

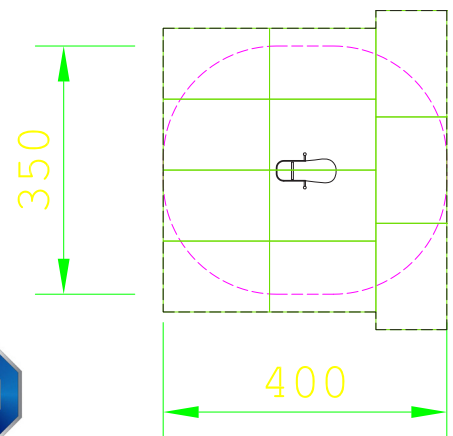

Product Name	Rhino Springer
Product Code	90840225RO
Material	BS EN 350-02 Class 1 Robinia Timber
Product Category	FHS Equipment for Small Children Springer
Age Range	2 to 6
Product Type	Moving Springer
Fixings	Stainless Steel Fixings & Galvanised Plates
Free Space Area m2	11.80
Free Space Loosefill m2	11.80
FFH	1.00
Area Required (LxW)	4 x 3.5
Grassmat Total (M ²)	6

Plan View
 Not to scale

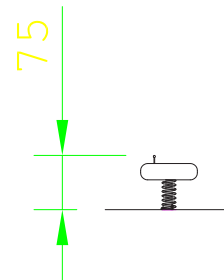

Compliant to EN1176

Product Description

The Rhino Springer is designed for children aged 2-6 years. The design of our springers is based on creatures and items that young children can identify with such as animals. Our range of springers encourage children's imagination and allow them to experience a range of movement.

The Inclusive Play logo highlights the pieces of equipment most suitable to users of varying abilities.

www.jupiterplay.co.uk
info@jupiterplay.co.uk

HEAD OFFICE: 0131 445 7989
 SOUTHERN OFFICE: 0115 969 9859